

Evaporators and air coolers REV, RGV and RBV

Series R_V is consisting of evaporators and air coolers for small cold rooms. These units are designed for fast cooling down and freezing for one or two trolleys of bakery gastronomy products, with temperature from -40 to +20°C.

These units are available with different type of refrigerants:

- Dry expansion evaporators HFC
- Air coolers for no frost solutions
- Dry expansion evaporators CO₂

Capacity range from 19 to 53 kW



Casing

The frame design provides high rigidity.

Casing manufactured from galvanized steel powder painted colour RAL 9002, corrosion resistant.

All rivets and bolts are in stainless steel AISI 304.

Heat exchanger

Heat exchanger is equipped with suspending tubes system that avoid the contact between tubes and frame and it provides full protection of the heat exchanger against vibrations and thermal expansions.

The coil is realized with copper pipes (rippled for REV and RBV to grant high efficiency and optimal evaporation, smooth for RGV diam. 12 mm minimum thickness 0,3 mm) and aluminium fins.

Evaporators HFC: PS 30 bar and TS -40 / +120 °C, according to standards PED 2014/68/EU.

Evaporators CO₂: PS 33, 45 and 60 bar and TS -45 / +120 °C, according to standards PED 2014/68/EU.

Air coolers: PS 16 bar and TS -40 / +120 °C, according to standards PED 2014/68/EU.

Fans

High efficiency fans provide high performances with limited power consumption. They are complete of thermal protection, protection grid according to EN ISO 13857, dynamically and statically balanced and according to ErP directive.

AC and EC fans are available with diameter 450 and 500 mm with motors with external rotor, insulation class F, standard protection degree IP 54 (EN 60529).

Standards

The products are designed and manufactured according to following EU Directive:

- PED 2014/68/UE
- 2006/42/CE (Machinery Directive)
- 2014/35/UE (LVD Directive)
- 2014/30/UE (EMC Directive)

Options

- Fins spacing 8,0 – 10,0 mm
- Stainless steel pipes AISI 304 or AISI 316L
- Stainless steel fins AISI 304 or AISI 316L
- Stainless steel grids AISI 304
- Epoxy coated aluminum fins
- Protective coating on coil
- Fins alloy AlMg
- Insulated drip tray
- Electric defrost
- Fans ring heaters
- Drain outlet heater
- Switch off for each fan
- AC and EC fans
- Stainless steel casing AISI 304 or AISI 316L

Code key

R	E	V	050	2	H	6	A	4	D
1	2	3	4	5	6	7	8	9	10

1. Refteco
2. Type of refrigerant (E = HFC, G = glycol, B = CO2)
3. Vertical coil
4. Fan diameter (mm)
5. Number of fans
6. Size of coil (number of rows)
7. Fins spacing (mm)
8. Type of defrost (A = air, E = electric)
9. Poles number of fans
10. Fans connection (D = triangle, Y = star)

Dimensions

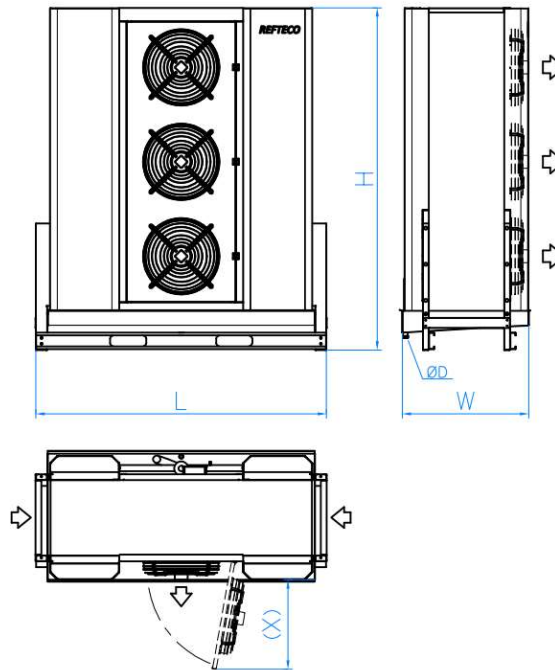

Model	Dimensions (mm)				
	L	W	H	X	D
0453	2000	870	2000	534	1"
0503	2000	870	2355	615	1"

Warranty

Products are granted, against any construction defect, for 24 months from shipping date. Damage caused by normal wear, corrosion, faulty assembly or maintenance are excluded.